

# Assembly Instructions

English



Grundig SAT Systems

## Head-End Digital Modulator

**HDM 483 TPS**  
**HDM 484 TPS**  
**HDM 485 TPS**



GSS  
Grundig SAT Systems GmbH  
Beuthener Straße 43  
D-90471 Nuremberg

Phone: +49 (0) 911 / 703 8877  
Fax: +49 (0) 911 / 703 9210  
Email: [info@gss.tv](mailto:info@gss.tv)  
Internet: <http://www.gss.tv>

# Contents

<b>1 Safety regulations .....</b>	<b>4</b>
<b>2 General information .....</b>	<b>4</b>
2.1 Packing contents .....	4
2.2 Technical data .....	5
2.3 Description .....	6
2.3.1 Software versions .....	7
2.3.2 How the TP module works .....	7
2.3.3 Explanation of the term "symbol rate" .....	8
2.3.4 Bandwidth-efficient assignment of cable channels with low bandwidths (SelecPlex®) .....	9
<b>3 Assembly .....</b>	<b>10</b>
3.1 Installing the Cassette .....	10
3.2 Connecting the Cassette .....	10
<b>4 The operator control panel at a glance .....</b>	<b>11</b>
4.1 Menu items .....	11
4.2 Operator control panel .....	11
<b>5 Programming .....</b>	<b>12</b>
5.1 Preparation .....	12
5.2 The menus at a glance .....	13
5.2.1 Standard menu (without cableDSL) .....	13
5.2.2 Menu with cableDSL optional equipment .....	16
5.3 Cassette programming (without cableDSL) .....	18
Selecting the Cassette .....	18
Switching the channel strip .....	18
To query software versions .....	19
Setting the output channel .....	19
Modulator settings .....	21
Setting output level of the channel strips .....	21
Producing a QAM signal for testing .....	22
Inverting the user signal .....	23
QAM monitoring .....	23
Deleting a PID .....	24
Renaming a PID .....	25
Conditional Access Table .....	26
Setting the LNB oscillator frequency .....	27
Setting the input symbol rate .....	28
Setting the input frequency .....	28
Setting the station filter .....	30
Setting the QAM modulation value .....	31
Setting the stuffing .....	32

	Network Information Table (NIT) .....	33
	Saving settings .....	34
5.4	Cassette programming (with cableDSL).....	35
	Selecting the Cassette .....	35
	Switching the channel strip.....	36
	Setting the network/provider identification .....	37
	Setting the stuffing / Saving settings .....	37

# 1 Safety regulations



## Important

- Assembly, installation and servicing must be carried out by an authorised electrician.
- Switch off operating voltage before the start of assembly or service work or pull out the mains plug.
- Install the system ...
  - in a dust-free, dry environment
  - so that it is protected from moisture, vapours, splashing water and damp
  - somewhere protected from direct sunlight
  - away from the immediate vicinity of heat sources
  - at an ambient temperature of  $< 50\text{ }^{\circ}\text{C}$ .
- Make sure the device is adequately ventilated.  
Do not cover the ventilation slots.
- Beware of short circuits!
- No liability is accepted for damage caused by faulty connection or inexperienced handling.
- Observe the relevant norms, regulations and guidelines on the installation and operation of antenna systems.
- Earth the SAT receiver using the equipotential bonding rail in accordance with DIN EN 50083 and VDE 0855.
- Do not perform installation and service work during thunderstorms.



**Take action to prevent static discharge when working on the device.**

## 2 General information

### 2.1 Packing contents

- 1 Cassette HDM 483 TPS or HDM 484 TPS or HDM 485 TPS
- 2 HF connection cables
- 1 CD (Assembly instructions)

## 2.2 Technical data

The devices meet the following EU directives:  
73/23/EEC, 89/336/EEC

The product fulfils the guidelines and standards for CE labelling.



### HF input:

Frequency range:	950 ... 2150 MHz
Frequency raster:	1 MHz
Level range:	35 dB $\mu$ V ... 80 dB $\mu$ V
IF bandwidth:	36 MHz
Symbol rate:	1...30 MSymb./s., MCPC/SCPC

### HF output:

#### HDM 483 TPS

Frequency range:	112 MHz ... 306 MHz
------------------	---------------------

#### HDM 484 TPS

Channels:	S21 ... S41
Frequency range:	306 MHz ... 466 MHz
Channel raster:	8 MHz

#### HDM 485 TPS

Channels:	C21 ... C69
Frequency range:	474 MHz ... 858 MHz
Channel raster:	8 MHz

**Output level:** Typ. 90 dB $\mu$ V

**Output impedance:** 75  $\Omega$ , nominal

### Connections:

SAT inputs:	2 F-connectors
HF output:	1 IEC socket, female
Connection strip (10-pin):	For supply voltages and control circuits
Socket RS 232:	Update interface

## 2.3 Description

The Cassettes convert two QPSK-modulated signals into two QAM-modulated data flows. The Cassettes are controlled via the head end.

Each Cassette has two inputs and one HF output.

Each Cassette is equipped with two channel strips (A and B). The channel strips consist of the digital SAT tuners, the digital signal preparing units and the output converters. The Cassettes' channel strips are indicated by Box "...A" or Box "...B" in the control unit display.

The integrated TP module (Transport Stream Processing) processes the data from the demodulated transport flow. In this way, service information can be modified (NIT – Network Information Table), data rates can be increased (Stuffing) and individual programs can be deleted from the transport flow, while the rest of the programs can be transmitted with optimised bandwidth. Furthermore, the operator ID (required for visAvision, for example) can be set.

With a change of software, channel A can be used for the implementation of the cableDSL data service. You can find the software "cableDSL" on the website "[www.gss.tv](http://www.gss.tv)". Channel B will continue to have the above-mentioned TP functions.

The operating software of the Cassette can be actualised via the 9-pin SUB-D-socket, using a PC or notebook (software "**BE-Flash**"). You can find the current operating software of the Cassettes on the website "[www.gss.tv](http://www.gss.tv)".

The prepared input signals are transmitted to the HF output collector of the head end via the HF output socket. The output level of the Cassettes can be set with the level regulator (max. -20 dB) at the output collector of the head end.

After the head end has been switched on, the software version of the control unit is displayed briefly in the two-line LC display and afterwards the type of Cassette of the first slot.

Approximately five minutes after the last button has been pressed, the software version of the control unit is displayed.

The Cassettes are designed for use in the following head ends:

- STC 316
- STC 332
- STC 1200
- STR 19-8

### 2.3.1 Software versions

#### **Cassette**

The inquiry of the Cassettes' software versions is described in chapter 5.

#### **Control unit**

If necessary, you can call up the display of the software version of the control unit manually:

- Hold down any two keys of the control unit simultaneously until the display goes dark and the software version, e.g. "V 35", is displayed.

### 2.3.2 How the TP module works

When converting the QPSK-modulated signal to a QAM-modulated cable signal, the demodulated data stream can be accessed via the integrated TP module. This data stream, also called transport stream, contains several stations with all their components (video, audio, data and service information), which can be changed using the TP module.

#### **The individual functions**

##### **Station filter**

Individual stations can be deleted. This reduces the data rate and, consequently, a lower output symbol rate can be selected.

##### **Stuffing**

The transport stream is padded out using what is known as zero data. This increases the data rate and, consequently, the output symbol rate. Changing the output symbol rate suitably alters the bandwidth used (halving the output symbol rate roughly halves the bandwidth at the output).

##### **Changing service information**

The transport stream contains data in the form of tables which the receivers evaluate and require for convenient use. The TP module can change the "Network Information Table" (NIT) to the new data of the stations. The NIT contains data which the set-top box needs for the automatic search function.

### 2.3.3 Explanation of the term “symbol rate”

Modulation schemes such as QPSK and QAM transmit multiple bits simultaneously. These are referred to as symbols. In addition to the user data flow which transmits video and audio information, error correction bits are transferred. The FEC number states the ratio of error correction bits to user bits. The output symbol rate is calculated as follows:

$$256\text{-QAM: } \mathbf{SR (A)} = \text{FEC} \times \frac{1}{4} \times \text{SR (E)}$$

$$128\text{-QAM: } \mathbf{SR (A)} = \text{FEC} \times \frac{2}{7} \times \text{SR (E)}$$

$$64\text{-QAM: } \mathbf{SR (A)} = \text{FEC} \times \frac{1}{3} \times \text{SR (E)}$$

$$32\text{-QAM: } \mathbf{SR (A)} = \text{FEC} \times \frac{2}{5} \times \text{SR (E)}$$

$$16\text{-QAM: } \mathbf{SR (A)} = \text{FEC} \times \frac{1}{2} \times \text{SR (E)}$$

$$4\text{-QAM: } \mathbf{SR (A)} = \text{FEC} \times \frac{1}{1} \times \text{SR (E)}$$

#### Example:

Output symbol rate 64-QAM,  $\text{FEC} = \frac{3}{4}$ ,

Input symbol rate  $\text{SR (E)} = 27,500$  kilosymbols per second

$$\mathbf{SR (A)} = \frac{3}{4} \times \frac{1}{3} \times 27,500 \text{ kilosymbols/s}$$

$$\mathbf{SR (A)} = \mathbf{6,875 \text{ kilosymbols/s}}$$

#### Note:

If no “FEC” is stated in the station lists, it can be assumed to be “ $\text{FEC} = \frac{3}{4}$ ”.

#### Reception from a transponder with a very low symbol rate (SCPC station)

The extremely low data rate means that the output symbol rate is very low. If there are reception problems with different digital receivers, set QAM modulation with stuffing to a higher value.

#### Defined symbol rates

Some cable operators specify a fixed symbol rate (e.g. 6,900 kilosymbols per second).

### 2.3.4 Bandwidth-efficient assignment of cable channels with low bandwidths (SelecPlex®)

Channels with low bandwidths are the result of filtering out stations which are not required. These “narrow” channels can then be arranged in one channel to save space. To do this, activate fine tuning in the “**Output channel**” menu (assignment outside the official channel raster).

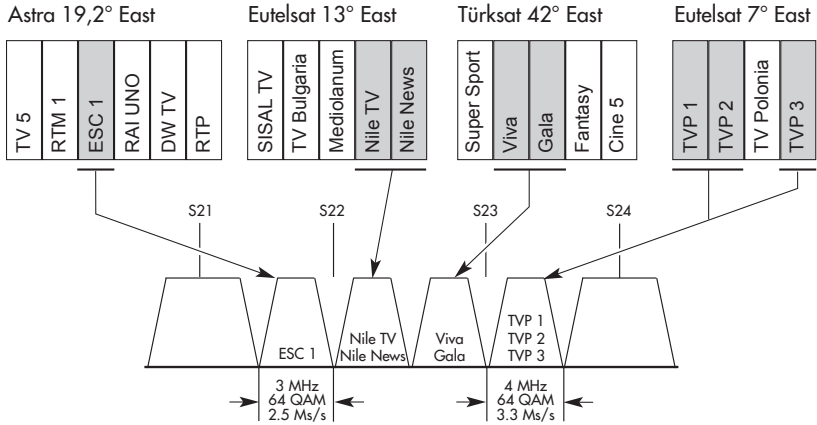

**Note:**

The required bandwidth is roughly equal to the symbol rate plus 20% in MHz.

## 3 Assembly

### 3.1 Installing the Cassette



#### Warning

Before inserting or changing Cassettes, pull the mains plug of the head end out of the mains socket.

- Unscrew the fastening screws from the bracket in the head end.
- Insert the Cassette into a free slot and push it into the housing.
- Align the Cassette and gently make it contact with the connections of the circuit board and the HF bus bar.
- Fasten the Cassette with the ① screws.

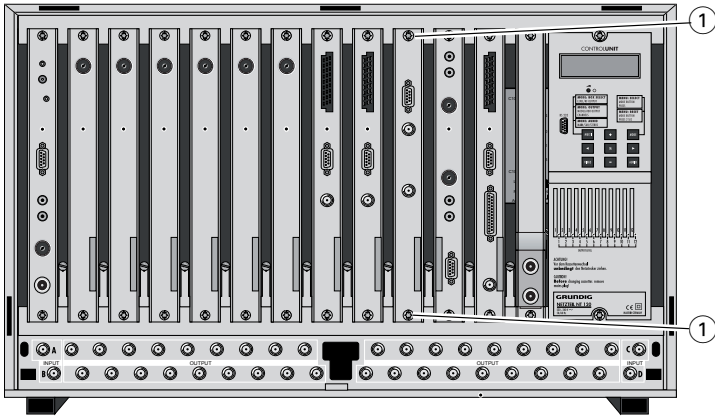

### 3.2 Connecting the Cassette

- Connect the HF input cable with the input sockets "INPUT A" ② (channel strip A) and "INPUT B" ① (channel strip B).
- Connect the head end to the mains power supply.  
—> The Cassette is now ready for operation.

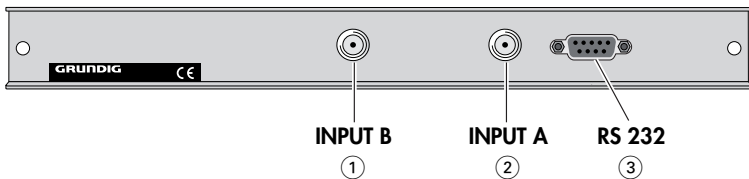

**Note:**

The operating software of the Cassette can be updated via the socket "RS 232" ③ (9-Pin-Sub-D) by means of a PC or notebook.

Use the "BE-Flash" software as the update software. You can find the current operating software of the Cassettes on the website "[www.gss.tv](http://www.gss.tv)".

## 4 The operator control panel at a glance

### 4.1 Menu items

Program the Cassette using the keys on the head end control unit. The two-line display of the control unit then shows the menus.

You can select the following main menu items with the **MODE** button:

- Cassette and channel strip
- Output channel
- LNB oscillator frequency
- Symbol rate
- Input frequency
- Network-/Provider Identification (cableDSL only)
- Station filter
- QAM modulation
- Stuffing
- Network Information Table (NIT)

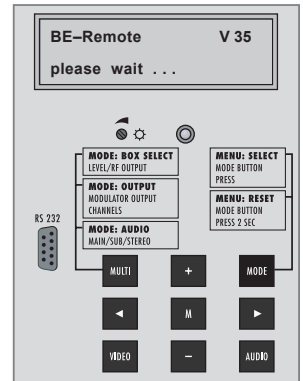

### 4.2 Operator control panel

You can individually select the menus and menu items step-by-step using the key pad of the head end:

- MODE** scrolls forward through the menu
- AUDIO** scrolls backward through the menu
- ←/→** select parameters in the menus
- +/-** set values, initiate actions
- MULTI** selects sub-menus
- M** saves all entries

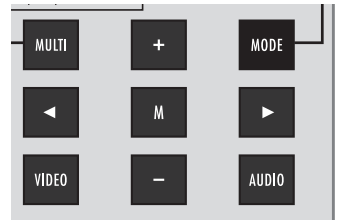

The parameters to be set are displayed underlined (cursor).

## 5 Programming

The following examples show how the HDM 484 TPS Cassette is programmed; the output channels can be set from S21 ... S41. Set the other Cassettes listed in the same way.

### 5.1 Preparation

#### Notes:

- Using the menu “**LEVEL CONTROL**” the Cassette generates an equally powerful HF carrier on the video carrier frequency of the channel. In this way, the Cassette’s level can also be set with an analogue TV test receiver set to the video carrier frequency of the channel.
- In order to prevent interference within the head end and the cable system, the output level of the digital Cassettes must be lowered by approx. 10 dB at 64 QAM and by approx. 4 dB at 256 QAM compared to analogue Cassettes.
- Balance the output levels of the channel strips “**A**” and “**B**” if the difference in level is  $\geq 1$  dB (see chapter “Setting output level of the channel strips”, page 21).

## 5.2 The menus at a glance

### 5.2.1 Standard menu (without cableDSL)

The standard menu shows the programming sequence using the example of channel strip "A". Programming for channel strip "B" is to be carried out in the same way.

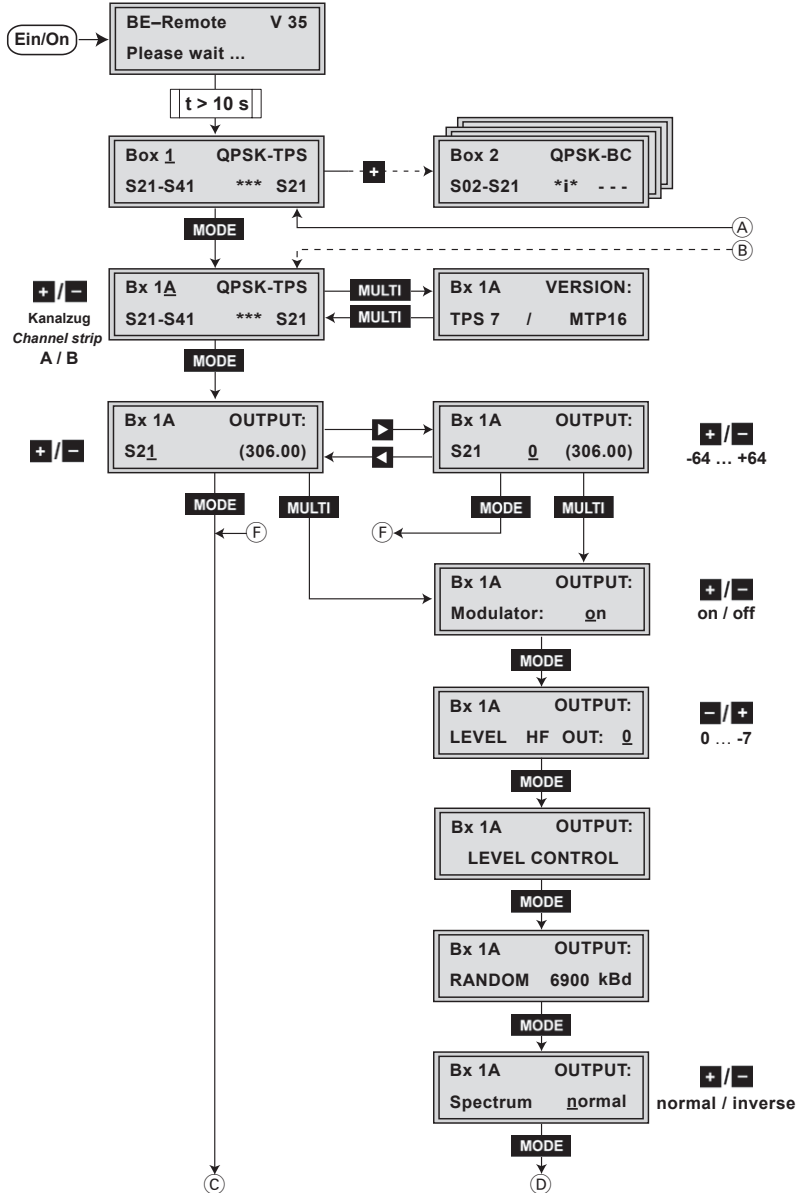

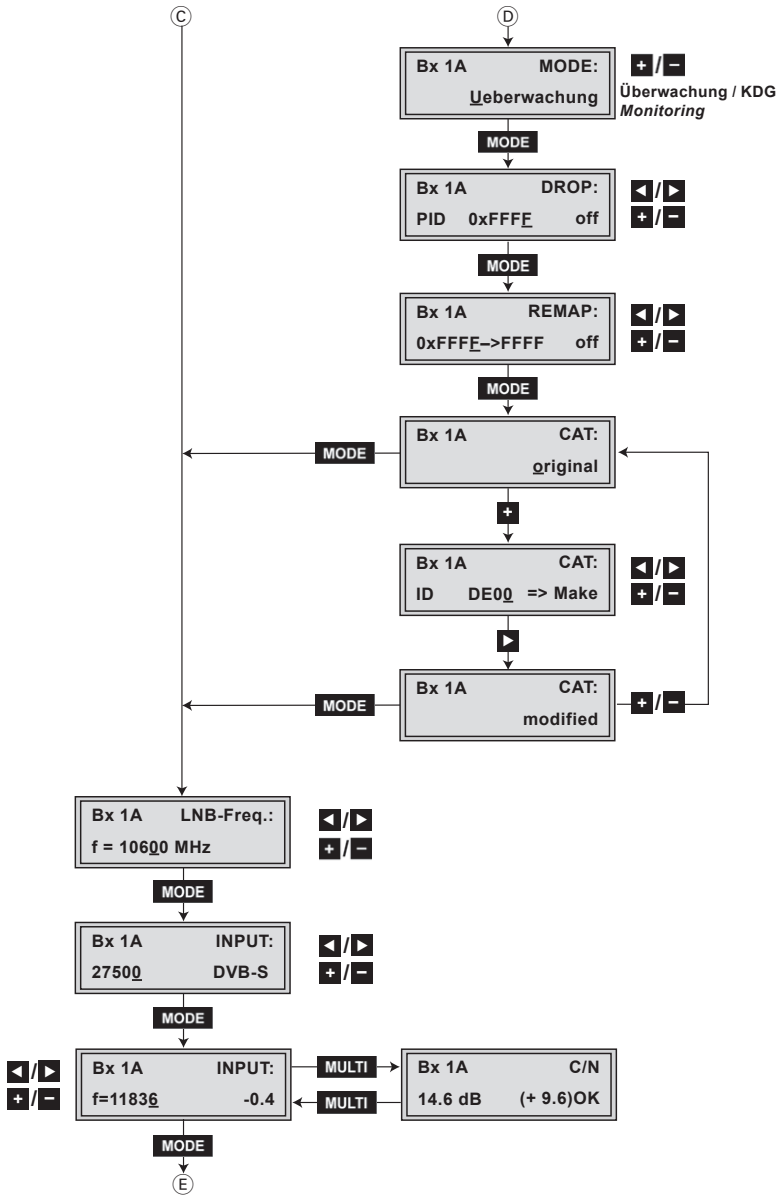

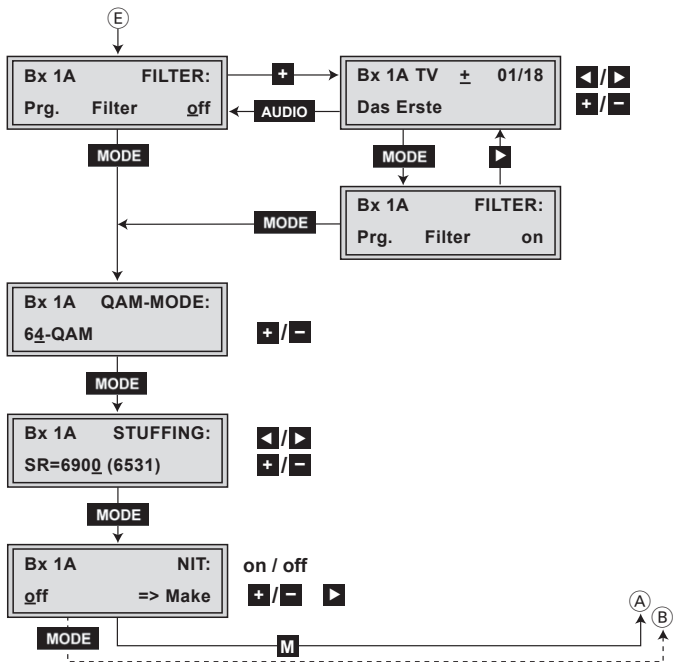

## 5.2.2 Menu with cableDSL optional equipment

If the operating software for cableDSL operation is subsequently loaded, the programming for channel strip "B" remains unchanged. Programming for channel strip "A" must be carried out according to the following menu.

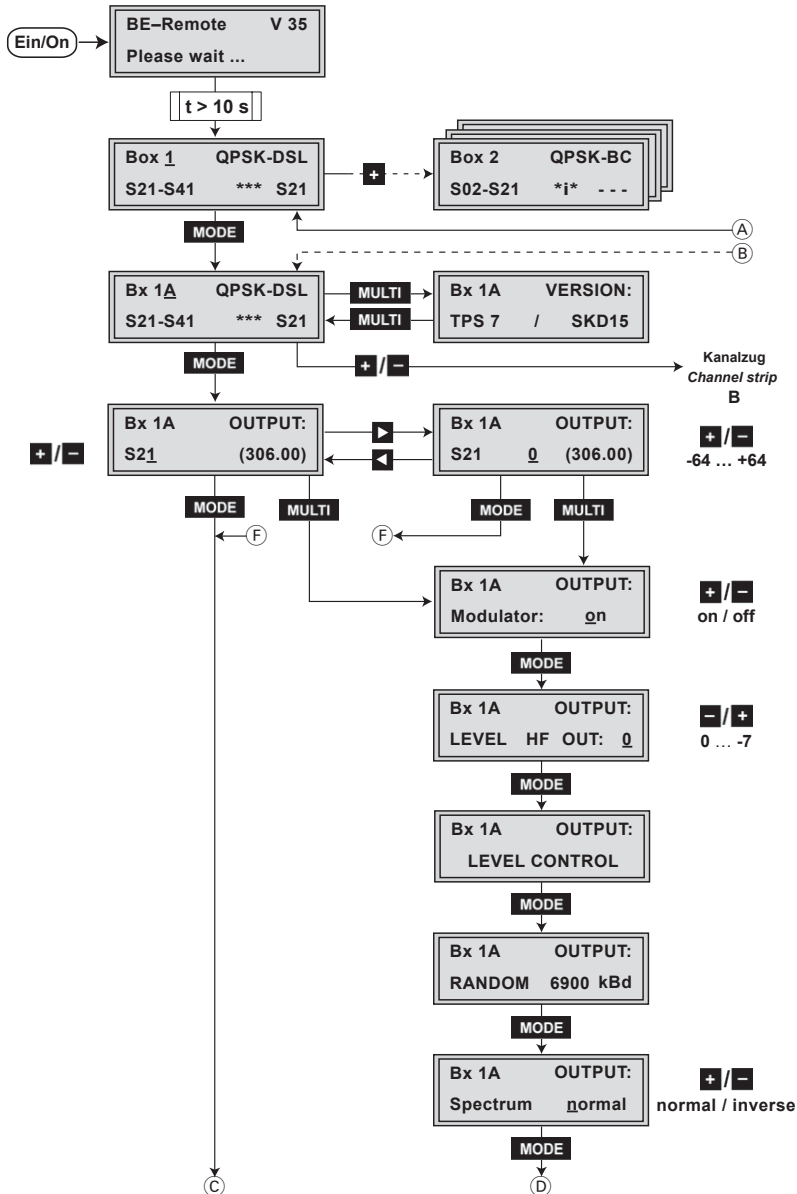

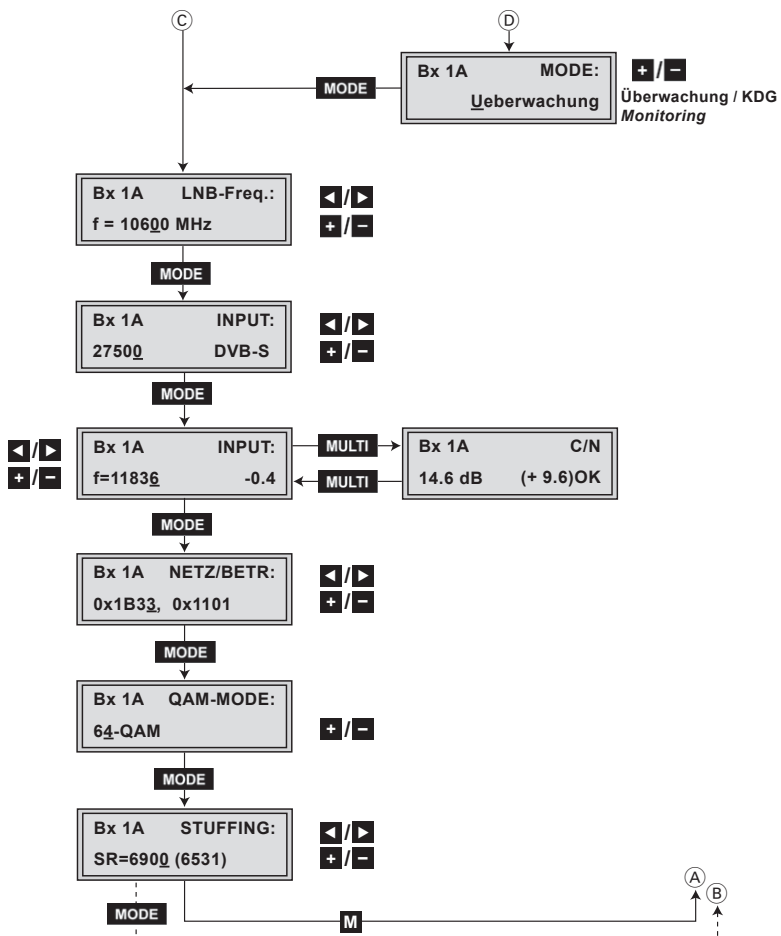

### 5.3 Cassette programming (without cableDSL)

- Switch on the head end.
  - The display shows the software version of the head end (e.g. V 35).
  - The processor reads the Cassettes' data (approx. 10 seconds).

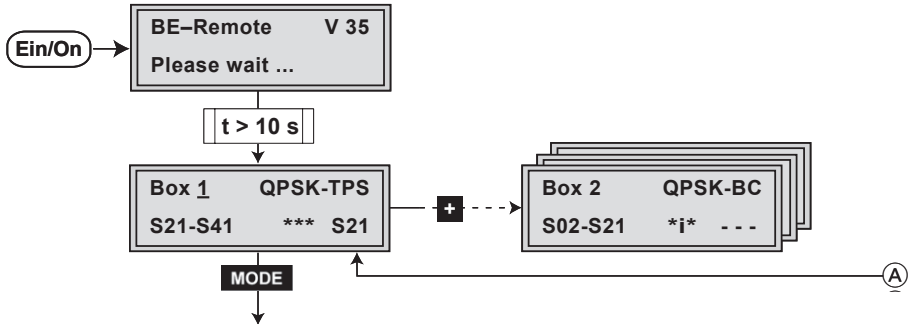

#### Selecting the Cassette

- If necessary select the Cassette you want to program (Box...) by repeatedly pressing the button **+**.
- By pressing **MODE**, activate channel strip "A".

#### Switching the channel strip

→ The display shows e.g. the menu "Bx 1A QPSK-TPS".

"Bx"	Cassette (box)
"1"	Cassette 1
"A"	Channel strip "A"
"S21-S41"	Adjustable channel range
"***"	Functions of the TP module
"S21"	Set channel

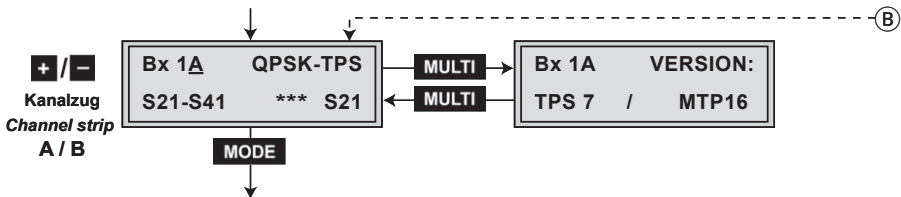

- Select the desired channel strip "A" or "B" with **+ / -**.

## To query software versions

- Software version of the Cassette and the TP module:  
Press the **MULTI** button.
- Return to main menu:  
Press the **MULTI** button again.
- Press the **MODE** button.  
→ The menu "Setting the output channel" – "OUTPUT" is activated.

## Setting the output channel

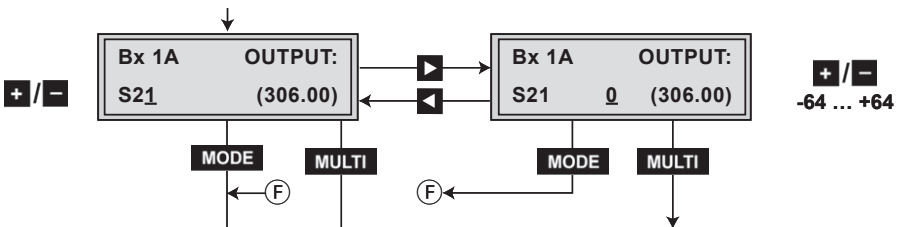

- By pressing **+/-**, set the desired output channel.  
→ The channel range that can be set depends on the type of Cassette used.

## Frequency offset (fine tuning)

- Press the **▶** button until "0" also appears in the display.
- Use the keys **+/-** to set the offset (-64 ... +64).
- If necessary, use the **◀** key to return to the channel setting.

### Note:

Using the Cassette HDM 483 TPS the menu "Setting the output frequency" appears instead of "Setting the output channel".

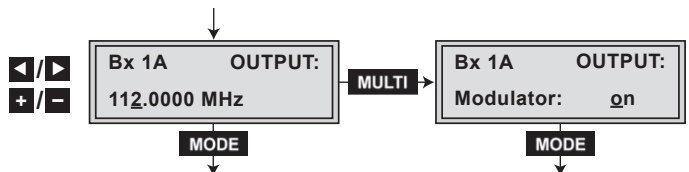

The QAM signal is transmitted with a bandwidth of 8 MHz. This means that you can only use the channel centre frequency of the existing channel raster in the range of channels S21 ... C69 (frequency raster 8 MHz). The frequency raster is 7 MHz in the range of the lower channel ranges (channels S2 ... S20). If one uses the existing channel raster here, this will result in interference (overlapping) of the 8 MHz QAM signal packages and thus transmission problems. For programming in this channel range, we recommend to calculate the output frequency of the QAM modulator,

- ... starting with the upper output frequency of the Cassette listed in the "Specifications" going back in steps of 8 MHz, or
- ... starting with the lower output frequency of the Cassette listed in the "Specifications" moving up in steps of 8 MHz.

Channel	Channel centre frequency [MHz]	Channel	Channel centre frequency [MHz]	Channel	Channel centre frequency [MHz]	Channel	Channel centre frequency [MHz]	Channel	Channel centre frequency [MHz]
S 21	306.00	S 35	418.00	C 28	530.00	C 42	642.00	C 56	754.00
S 22	314.00	S 36	426.00	C 29	538.00	C 43	650.00	C 57	762.00
S 23	322.00	S 37	434.00	C 30	546.00	C 44	658.00	C 58	770.00
S 24	330.00	S 38	442.00	C 31	554.00	C 45	666.00	C 59	778.00
S 25	338.00	S 39	450.00	C 32	562.00	C 46	674.00	C 60	786.00
S 26	346.00	S 40	458.00	C 33	570.00	C 47	682.00	C 61	794.00
S 27	354.00	S 41	466.00	C 34	578.00	C 48	690.00	C 62	802.00
S 28	362.00	C 21	474.00	C 35	586.00	C 49	698.00	C 63	810.00
S 29	370.00	C 22	482.00	C 36	594.00	C 50	706.00	C 64	818.00
S 30	378.00	C 23	490.00	C 37	602.00	C 51	714.00	C 65	826.00
S 31	386.00	C 24	498.00	C 38	610.00	C 52	722.00	C 66	834.00
S 32	394.00	C 25	506.00	C 39	618.00	C 53	730.00	C 67	842.00
S 33	402.00	C 26	514.00	C 40	626.00	C 54	738.00	C 68	850.00
S 34	410.00	C 27	522.00	C 41	634.00	C 55	746.00	C 69	858.00

- Press the **MODE** button.
  - The menu "Setting the LNB oscillator frequency" – "LNB-Freq.:" is activated (page 27).

or

- Press the **MULTI** button.  
 → The sub-menu “Modulator settings” –  
 “**OUTPUT: Modulator**” is activated.

### Modulator settings

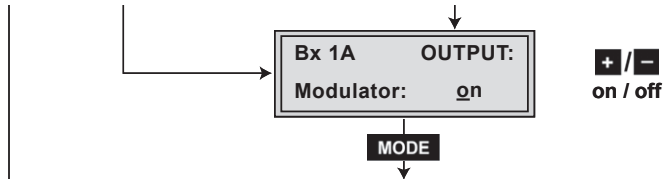

- By pressing the **+ / -** buttons, switch the modulator (HF output) “on” (default setting) or if necessary switch it “off”.
- Press the **MODE** button.  
 → The menu “Setting output level of the channel strips” –  
 “**OUTPUT: LEVEL HF OUT:**” is activated.

### Setting output level of the channel strips

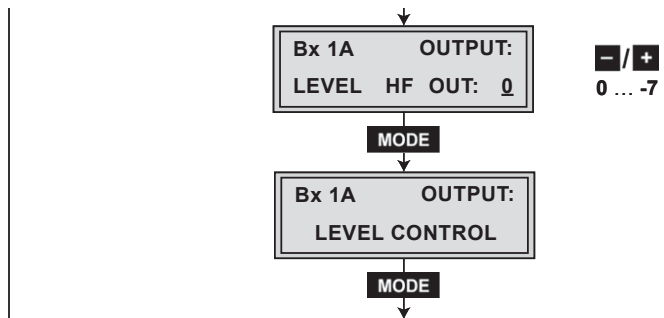

- Press the **MODE** button.  
 → “**OUTPUT: LEVEL CONTROL**” appears in the display.

#### Note:

In this mode a digital carrier is set to the analogue picture carrier frequency of the output channel of the respective channel strip. Thus you can measure the absolute output level using a analogue test receiver.

- Measure the output level of the channel strip using the connected antenna test receiver and note the measured value.
  - Setting the second channel strip compare the measured value with the noted value of the first channel strip.
  - If the measured value of the first channel strip is higher press the **AUDIO** button repeatedly to activate this channel strip (page 18).
  - In the menu **"OUTPUT: LEVEL HF OUT:"** adjust the higher output level of one channel strip to the lower output level of the other channel strip incrementally from **"0"** to **"- 7"** dB by pressing **-/+**.
- Press the **MODE** button.
  - The menu "Producing a QAM signal for testing" – **"OUTPUT: RANDOM"** is activated.

### Producing a QAM signal for testing



The Cassette generates a QAM signal for testing, without there having to be an input signal. In the second menu line, the corresponding output symbol rate e.g. **"6900 kBd"** (= 6,900 kilosymbols per second) is shown.

- Press the **MODE** button.
  - The menu "Inverting the user signal – **OUTPUT: Spectrum"** is activated.

## Inverting the user signal

For exceptions and “older” digital cable receivers, the spectral position of the user signal can be inverted.

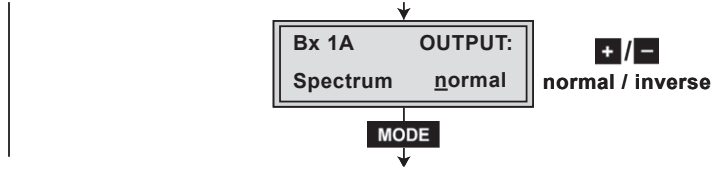

- By pressing **+ / -** , set the spectral position “normal” or “inverse”.
- Press the **MODE** button.  
→ The menu “QAM monitoring” – “**MODE:**” is activated.

## QAM monitoring

In this menu the signal at the Cassettes’ output is defined if there is no input signal available. Thus an automatic monitoring of the QAM modulated output signal is possible.

- “**Ueberwachung**” (Monitoring):  
For monitoring with the Monitoring Cassette a single carrier is output.
- “**KDG**”:  
For customer specific applications a QAM modulated data flow is output.

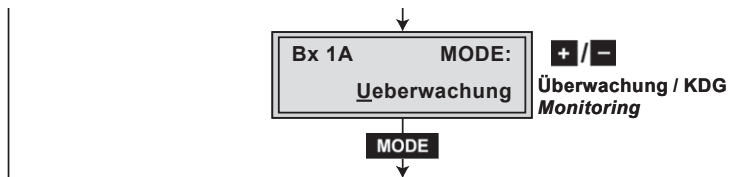

- Use **+ / -** to select “Ueberwachung” or “KDG”.
- Press the **MODE** button.  
→ The menu “Deleting a PID” – “**DROP PID**” is activated.

## Deleting a PID

In this menu a PID of the data flow can be deleted.

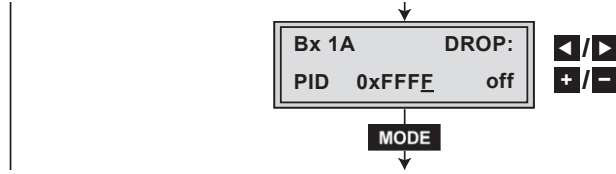

- Use the ◀/▶ buttons to place the cursor under the respective letter (hexadecimal number) of the PID to be deleted ("0xFFFF") and set the hexadecimal number using +/-.
- Use ▶ to set the cursor to "off" and switch to "on" (delete) using the +/- buttons.
- Press the **MODE** button.  
→ The menu "Renaming the PID" – "**REMAP**" is activated.

## Renaming a PID

In this menu you can allocate a new address to a PID retaining the complete data content.

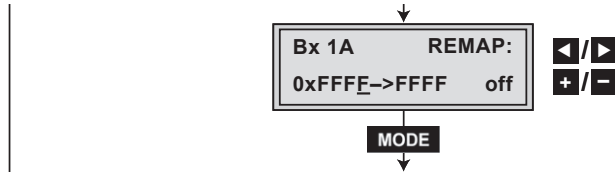

- Use the ◀/▶ buttons to place the cursor under the respective letter (hexadecimal number) of the PID to be changed ("0xFFFF") and set the hexadecimal number using +/-.
- Use the ◀/▶ buttons to place the cursor under the respective letter of the new PID to be set ("-> FFFF") and set the hexadecimal number using +/-.
- Use ▶ to set the cursor to "off" and switch to "on" (renaming) using the +/- buttons.
- Press the **MODE** button.  
→ The menu "Conditional Access Table" – "CAT" is activated.

## Conditional Access Table

In this menu, you can change the Operator ID, for example of the visAvision transponder (Eutelsat 8° West).

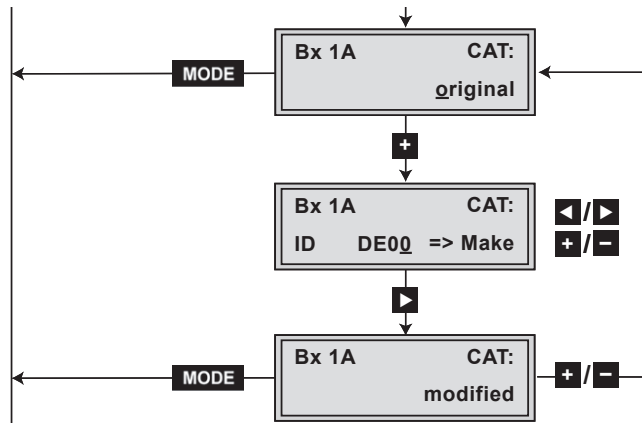

### CAT is not to be changed.

- Press the **MODE** button.  
→ The menu "Setting the LNB oscillator frequency" – "LNB-Freq.:" is activated (page 27).

### CAT is to be changed.

- Press the **+** button.  
→ The CAT is scanned and the changeable values (operator ID) are displayed.

### Note:

If you try to change the CAT of a transponder which cannot be modified, "**CAT not modified**" appears in the display for a short time. Afterwards the program returns to the "**CAT original**" menu.

### Example:

The network operator requests that you set the operator ID of the visAvision transponder to "2":

- Use **+/-** to change the values from "DE 00" to "DE 02".
- Press **▶** to activate "**Make**" to modify the operator ID.  
→ The menu display switches to "**modified**".

- If the operator ID is to be reset or changed:  
Press **+/−** to return to the CAT input menu "**Bx 1A CAT**". There the current operator ID is replaced by the original operator ID. The procedure "**CAT is to be changed**" can be repeated or by pressing the **MODE** button it can be cancelled.
- Press the **MODE** button.  
→ The menu "Setting the LNB oscillator frequency" – "**LNB-Freq.:**" is activated.

### Setting the LNB oscillator frequency

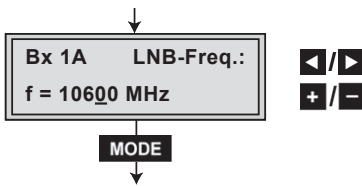

- Use the **◀/▶** buttons to place the cursor under the number to be changed and use **+/−** to set the oscillator frequency of the LNB used.
- Press the **MODE** button.  
→ The menu "Setting the input symbol rate" – "**INPUT**" is activated.

## Setting the input symbol rate

The symbol rate of the satellite transponder can be found in the current transponder tables of the various satellite trade magazines or in the websites of the according program providers.

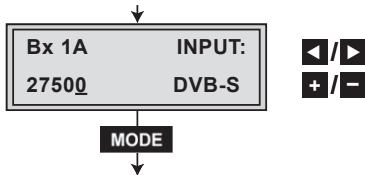

- Use the ◀/▶ buttons to place the cursor under the number to be changed and set the symbol rate with the buttons +/-.

**Note:** The logo "DVB-S" is without function.

- Press the **MODE** button.  
→ The menu "Setting the input frequency" – "INPUT" is activated.

## Setting the input frequency

### Notes:

- If three dots "..." appear in the second line of the display, the Cassette is in the "station search" mode. Please wait until the process has finished. Once the HF receiver has synchronised to the input signal, any offset to the target frequency is displayed in MHz, e.g. "-0.4".
- If a question mark "?" appears in the second line of the display, there is no input signal present. Check the configuration of the antenna system and head end as well as the preceding settings of the Cassette.

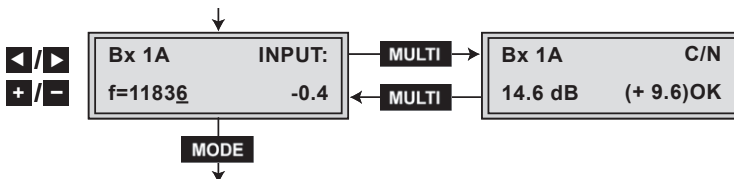

- Use the ◀/▶ buttons to place the cursor under the number to be changed and set the input frequency with the buttons +/-.
- Press +/- to adjust the input frequency so that the offset is less than 1 MHz.
- Press the **MULTI** button.
  - The sub-menu "Testing the signal to noise ratio" – "C/N" is activated.

### Testing the signal to noise ratio

In this menu you can estimate the quality of the input signal.

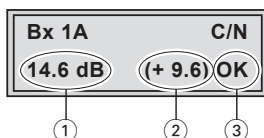

- ① Current signal to noise ratio
- ② This value shows the difference between the quality of the input signal and the threshold of the tuner at this type of modulation.

#### Note:

At a value lower than "5" picture dropouts can occur.

- ③ If "OK" is shown, the signal to noise ratio is OK. If a value < 5 is shown under ② the display changes from "OK" to "??".

- Press the **MULTI** button → Return to the main menu.
- Press the **MODE** button.
  - The menu "Setting the station filter" – "FILTER" is activated.

## Setting the station filter

The default setting for the station filter is "off".

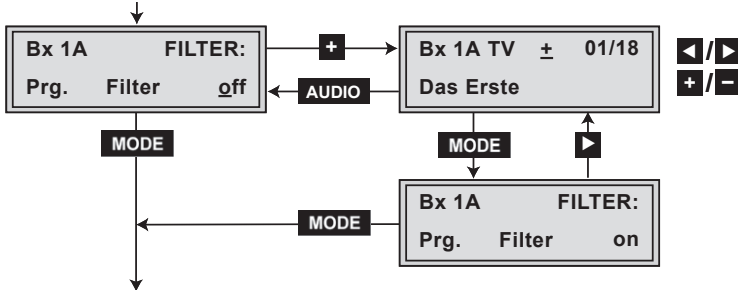

- Press the **+** button.

**All channels of channel strip** are scanned and displayed with name and channel type.

### Meaning of the terms displayed:

"Bx1A" – Cassette 1, channel strip A

"TV" – TV channel type

"RA" – Radio channel type

"+" – The channel that has just been selected is activated.

"-" – The channel that has just been selected is deactivated.

"01/18" – The 1st of 18 channels scanned is displayed

"Das Erste" – Channel name

- Select the stations to be removed by pressing **◀/▶**.
- To switch off stations, press the **-** button.
  - Switch the station back on again by pressing the **+** button if necessary.
  - To cancel station selection: Press the **AUDIO** button (filter "off").
- Save changes and activate the station filter: Press the **MODE** button.
  - The filter is activated ("Prg. Filter on"). The corresponding PID's (audio, video, text) are removed from the data flow and the PAT and SDT tables are updated. The data flow becomes narrower.

—> The station filter remains deactivated (“**off**”) if no station was removed.

- Test the status of the individual stations:  
If the filter is switched on, press the **▶** button. In this mode you can use **◀/▶** to select stations in the program table and activate switched off stations or switch off further stations by pressing the **+/-** buttons.

**Note:**

- If no station is found, the error message “**no Service**” appears.  
Check the configuration of the antenna system including the head end and the previous settings of the Cassette.

- Press the **MODE** button.  
—> The menu “Setting the QAM modulation value” – “**QAM-MODE**” is activated.

**Setting the QAM modulation value**

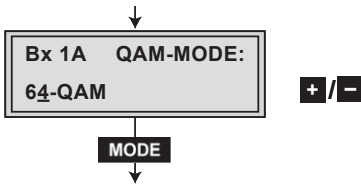

- Set the QAM mode with **+/-**.  
—> A higher QAM mode restricts the output symbol rate (permissible value < 7,000 kilosymbols per second).  
An output QAM mode of > 64 QAM places a large burden on the cable network. Due to noise, delay and frequency response problems, a reception of the converted output signal can be impeded.
- Press the **MODE** button.  
—> The menu “Setting the stuffing” – “**STUFFING**” is activated.

## Setting the stuffing

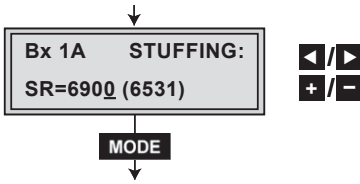

**SR=6900** (= "Number 1"): Active output symbol rate

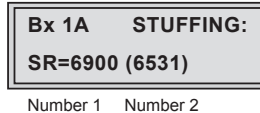

**(6531)** (= "Number 2"):

The current measured output symbol rate.

If the station filter is activated, this value is lower than the value of the "Number 1". The value fluctuates, since the data rates of individual stations are dynamically modified by the broadcasters.

- Use the buttons to place the cursor under the number to be changed ("Number 1") and set the symbol rate with the buttons . The value set corresponds to the new output symbol rate.

### Note:

- Increase the value of "Number 1"
  - The "Number 1" can be increased to any value up to 7,000.
- Reduce the value of "Number 1".
  - With the station filter switched "on", the "Number 1" can be decreased. To do this, observe the "Number 2" for 30 seconds and note the highest value. Add roughly 10 % to this value. Do not decrease the "Number 1" lower than the value of "Number 2". Is the "Number 1" lower than "Number 2" question marks "??" appear in the display.

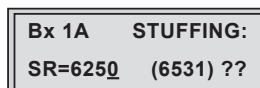

- Press the **MODE** button.  
 → The menu “Network Information Table” – “NIT” is activated.

### Network Information Table (NIT)

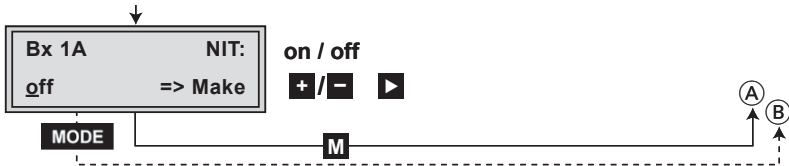

- To switch NIT “on” or “off”: Press the **+ / -** button.
- Activate “**Make**” by pressing **▶** .  
 → The NIT of all Cassettes are switched on.  
 → The Cassette gets all the information it needs (output frequencies, output symbol rates etc.) to generate the cable NIT from all the QAM Cassettes. This process may take a few seconds.  
 The display shows: “**Making ...**”.
- Then the NIT is generated, added and sent to all QAM Cassettes. The other QAM Cassettes also add this new cable NIT. The status of all QAM Cassettes in the NIT menu changes to “on”.
- To deactivate the new NIT: Press the **-** button.  
 → The SAT-NIT is restored.

#### Notes:

- The cable NITs of the other Cassettes remain activated. When it is reactivated (“on”), the previously generated NIT is added again. If you have changed parameters in the meantime, you must select “**Make**” to generate a new, up-to-date NIT.
- All QAM Cassettes must be equipped with a TP module, be set and ready for reception. Cassettes without TP modules are not taken into consideration during the NIT setting. If the NIT is activated (“on”) and parameters are modified and saved, a warning appears in the display: “**Rebuilt NIT !!!**”.

In this case, you must create a NIT ("**Make**"). The NITs of all the QAM Cassettes in the head end are thus automatically updated.

### Saving settings

- Press the **M** button.
  - Return to "Selecting the Cassette" **(A)** (page 18).
  - The "new" settings are saved permanently.
  - If functions of the TP module are activated, their status is shown in the second line of the display:
    - "**P**" – station filter on
    - "**C**" – CAT changed
    - "**N**" – NIT is activated

Functions that are not active are indicated by a star " \* ".

### Notes:

- Going back to "Switching the channel strip" **(B)** via **MODE** (page 18) cancels all settings that have not been saved.
- If necessary set channel strip "**B**".

## 5.4 Cassette programming (with cableDSL)

cableDSL (also called SKY-DSL) enables quick data access to the Internet via satellite. The return channel to an Internet server is realised via a telephone line connected to the head end.

Channel strip "A" is processed for "cableDSL". The corresponding programming is specified in the following. If steps of programming are already described in chapter 5.3, we refer to the corresponding setting.

Programming for channel strip "B" is to be carried out as described in chapter 5.3.

- Switch on the head end.
  - The display shows the software version of the head end (e.g. V 35).
  - The processor reads the Cassettes' data (approx. 10 seconds).

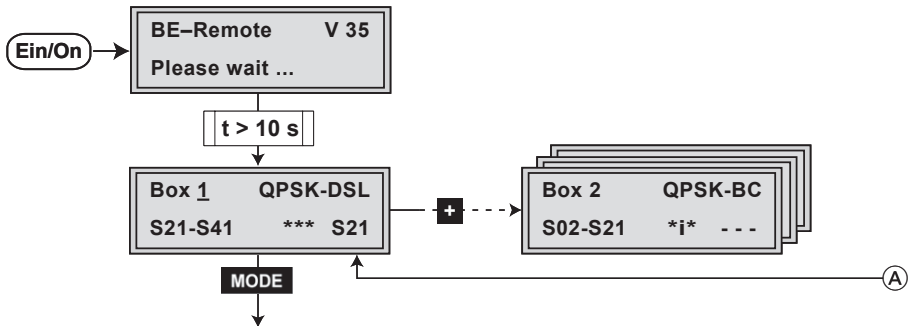

### Selecting the Cassette

- If necessary select the Cassette you want to program (Box...) by repeatedly pressing the button **+**.
- By pressing **MODE**, activate channel strip "A".

## Switching the channel strip

—> The display shows e.g. the menu "Bx 1A QPSK-DSL".

"Bx"	Cassette (box)
"1"	Cassette 1
"A"	Channel strip "A"
"S21-S41"	Adjustable channel range
"***"	Functions of the TP module
"S21"	Set channel

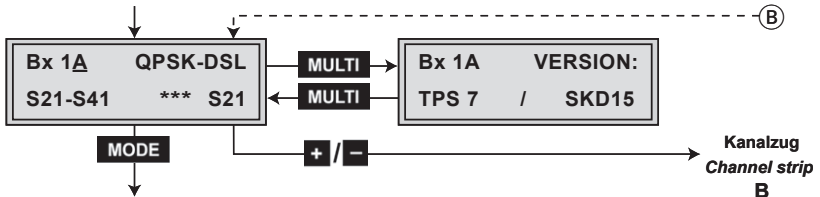

- If necessary select the channel strip "B" with **+ / -**.  
—> Program channel strip "B" according to chapter 5.3 (page 18).

Programming the channel strip "A" is as far as possible identically to the programming described in chapter 5.3.

Please note the following cross references:

- To query software versions (page 19)
- Setting the output channel (page 19)
- Frequency offset (fine tuning), (page 19)
- Modulator settings (page 21)
- Setting output level of the channel strips (page 21)
- Producing a QAM signal for testing (page 22)
- Inverting the user signal (page 23)
- QAM monitoring (page 23)
- Setting the LNB oscillator frequency (page 27)
- Setting the input symbol rate (page 28)
- Setting the input frequency (page 28)

## Testing the signal to noise ratio (page 29)

- Press the **MODE** button.  
—> The menu "Setting the network/provider identification"  
- "NETZ/BETR:" is activated.

## Setting the network/provider identification

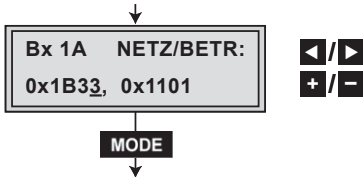

- Use the ◀/▶ buttons to place the cursor under the digit of the Network ID (network identification number) to be changed.
- Set the network identification number, deliverable by the program provider, with the buttons +/− (hex code).

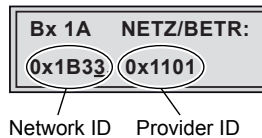

- Use the ◀/▶ buttons to place the cursor under the digit of the Provider ID (provider identification number) to be changed.
- Set the provider identification number, deliverable by the program provider, with the buttons +/− (hex code).
- Press the **MODE** button.  
→ The menu "Setting the QAM modulation value" – "QAM-MODE" is activated.

## Setting the QAM modulation value (page 31)

### Setting the stuffing / Saving settings

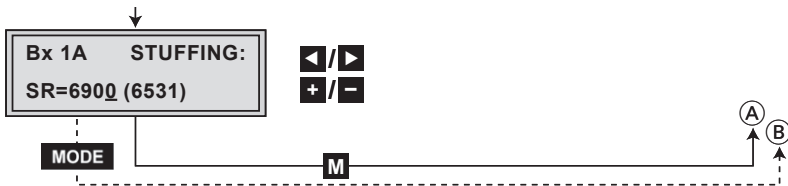

- Use the ◀/▶ buttons to place the cursor under the

number to be changed and set the symbol rate with the buttons **+**/**-** (see page 32).

- Press the **M** button.
  - > The “new” settings are saved permanently.
  - > Return to “Selecting the Cassette” **A** (page 18 / 35).
  - > If functions of the TP module are activated, their status is shown in the second line of the display:
    - “**S**” – cableDSL is activated
    - “**P**” – Program filter switched on
    - “**N**” – NIT is activated

Functions that are not active are indicated by a star “ \* ”.

**Notes:**

- Going back to “Switching the channel strip” **B** via **MODE** (page 18) cancels all settings that have not been saved.
- If necessary set channel strip “**B**”.



